

MADDEN PUMP

MF SERIES DIAPHRAGM METERING PUMPS

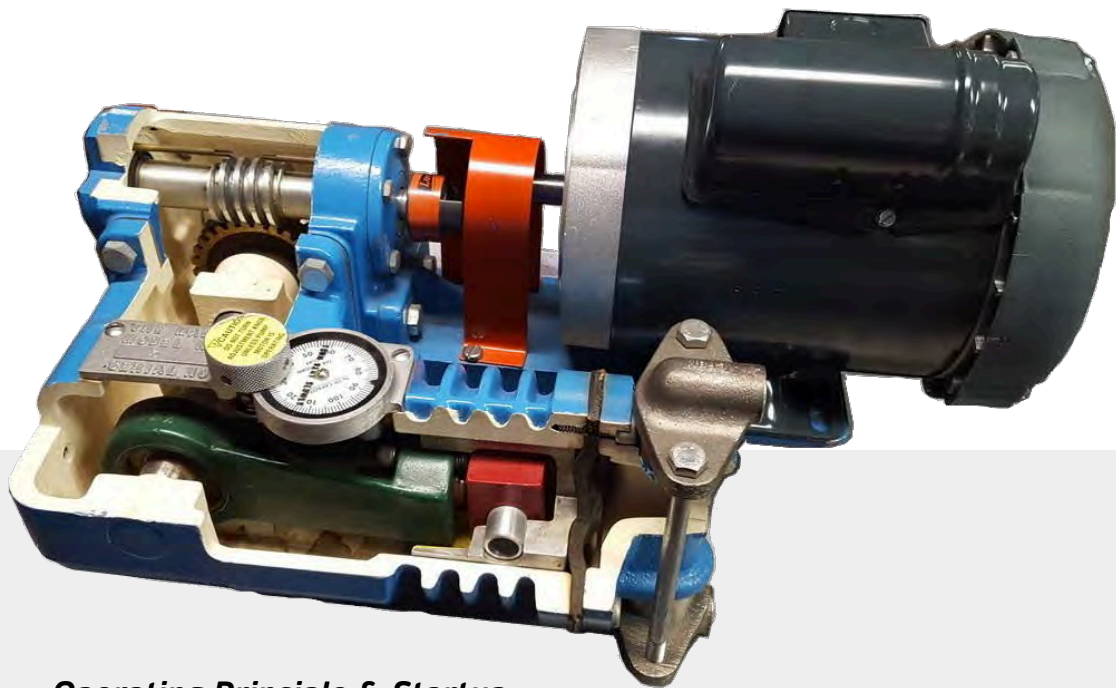

- Pg 1 Operating Principle & Startup*
- Pg 2-3 General MF Series Info*
- Pg 3 Lubricating Info*
- Pg 3-6 Parts List & Figures*
- Pg 7 Troubleshooting Tips*

OPERATING MANUAL & PARTS LIST

The MADDEN METRIFLOW PUMP has been designed for the movement of chemical solutions and slurries of all kinds plus the additional advantage of a controlled volume discharge. It is built for heavy duty, continuous service. When operated according to the simple directions contained herein, it will require minimum attention.

Although the pump is simple in both design and structure, it embodies several features not encountered in other pumps. To obtain the best results it is important that the user fully understand the principle of operation and the function of these several parts.

THE OPERATING PRINCIPLE

The cut-away photograph on the front cover shows the heavy duty, flexible diaphragm which is mechanically actuated by a large, three inch diameter piston that operates with the extremely short maximum stroke of approximately one quarter inch.

The diaphragm, 1/4" thick and reinforced with four plies of Nylon, has been imposed between the face of the pump body and the chemical solution head to act as a tough, durable dividing wall between the pumping mechanism and the chemical solution to be transferred. The pump can thus be provided (or simply and economically changed at any time) to handle almost all chemical or abrasive solutions by simply installing a diaphragm, solution head, and valves of the proper materials to meet the solution compatibility requirements. Thus, the materials in the pump body itself and the pump mechanism are standard in all cases, saving needless original or rebuilding costs in the case of a later change in solution requirements.

Simplicity of design; rugged construction; total, self-contained lubrication... all are built into the MADDEN METRIFLOW to give the longest possible service with the least amount of maintenance required.

A short study of the cut-away photograph will help to quickly familiarize the operator with the METRIFLOW pump and special attention is called to the improved "Micro-Control" stroke adjusting mechanism.

The dial scale has one hundred calibrations with reference numbers at every ten for quick, accurate capacity control. (See Capacity chart on Page 5.) It is directly geared to the Stroke Adjustment Knob. This knob also controls the Stroke Adjustment Screw through a Flexible Shaft.

This simplified control mechanism of the MADDEN METRIFLOW PUMP is practically free of wear because there is no movement except when a change in capacity is made. The "Micrometer" precision should last indefinitely.

With each revolution of the Eccentric, the Connecting Rod travels the full, maximum stroke along the two Slide Bolts.

"Lost Motion" space has been allowed between the forward end of the Connecting Rod and the Trunnion with the result that the movement of the Connecting Rod is not transmitted to the Piston until the Stroke Adjustment Screw is advanced by rotating the Adjustment Knob clockwise. Further advancement progressively reduces the "lost motion" space, thus transmitting an increasing portion of the Connecting Rod movement to the Piston. Final advancement will close the gap completely and the Piston will then travel full stroke and deliver the maximum discharge volume.

It should be remembered that at any point above zero (on the dial scale), the Piston will always be fully returned on the back stroke by the action of the Connecting Rod against the heads of the two Slide Bolts, while the amount of forward movement will be governed by the position of the Stroke Adjustment Screw. Increased forward movement likewise increases volume of discharge up to the maximum capacity of the pump.

WARNING!

To prevent pump damage, the operator should be cautioned that when complete forward advancement of the Stroke Adjustment Knob could result in damage to the Flexible Shaft. When changing stroke adjustment, the Adjustment Knob should be turned SLOWLY and ONLY when the pump is operating. Always watch the dial scale to avoid "overturning" in either direction. Turning the Adjustment Knob when the pump is not operating risks damage to the Flexible Shaft.

STARTING and PRIMING

Each MADDEN METRIFLOW PUMP and Gear Case shipped from the factory is filled with the right amount and kind of lubricating oil and is ready for service when piping and power connections are completed.

When starting the pump it should be remembered that a few moments operation will be required to fill the solution section with fluid and displace all air present before the pump will become fully primed. When first put into service, or if allowed to operate without liquid entering the solution chamber, the air contained therein will tend to compress and expand with the movement of the piston and thus hinder the flow and displacement of liquid.

If the solution supply is in such location as to assure gravity flow to the pump, the liquid entering the inlet valve will quickly displace the air and after a few moments' operation, the discharge volume should be at full capacity according to the piston stroke adjustment's setting. In the event that complete clearance of air is stunted due to excessive back pressure at the discharge valve, the priming process can be expedited by relieving the pressure for a few strokes of the pump (ex. bleed valve on discharge line).

Whenever possible, it is desirable to install the pump and solution source in such relative position as to assure gravity flow to the inlet valve. Inlet head pressure of several feet or pounds will not interfere with the action of the valves or pump provided the discharge pressure, or back pressure at the discharge valve, is in excess of the inlet pressure. In any instance where the inlet pressure is equal to, or in excess of, back pressure at the discharge valve, or where the supply source is at an elevation of one or more floors above the pump, it may be necessary to spring load the discharge valve to compensate for the unbalanced condition.

SUCTION LIFT

In some instances, individual conditions may make it necessary to install the pump at a point above, rather than below the solution supply, thus requiring a "suction lift". Although the MADDEN METRIFLOW PUMP is not intended for high vacuum service, it should be possible to obtain a lift of 6-10' when pump is in good working order.

In all instances where a suction lift is employed, it will be necessary to arrange means for priming the solution chamber in order to start the pumping process. This is easily accomplished by adding a tee to the intake line with a pipe spud of at least 6" extending vertically upward. This will expel the air in the chamber, avoid the churning due to compression and expansion and thereby enable the suction stroke to become effective.

In any service where "lift" rather than gravity flow is necessary, it is desirable to install a foot valve at the lowest point in the intake pipe to avoid losing the prime whenever the pump is out of service.

VOLUME CONTROL - See CAPACITY CHART page 3

The volume of fluid displaced is in proportion to the length of piston stroke. The length of stroke may be easily adjusted by turning the Stroke Adjustment Knob (on top of the pump). Turn clockwise to increase stroke for greater volume and counter clockwise to decrease.

The one hundred calibrations offer a high degree of adjusting accuracy plus simple operation and good visibility. Any change of stroke adjustment should be made slowly and always while the pump is running. The operator should always watch the dial scale while making adjustment to avoid excessive "over-turning" at either end of the scale which could result in damage to the flexible shaft connecting the Stroke Adjustment Knob with the Stroke Adjustment Screw.

DIAPHRAGM

The MADDEN METRIFLOW PUMP is designed to transfer almost every type and kind of fluid under many different conditions of volume, pH value, concentration, temperature, etc. Since there is no single substance for diaphragm use which will withstand every service, it is necessary to select materials according to the work to be performed. Within the limitation of availability, we endeavor to furnish diaphragms which will not only resist chemical attack, but will also have the required physical properties to assure long periods of service. We are constantly seeking new and better materials for this purpose and maintain extensive files of technical data pertaining to the properties of nearly all substances which may be usable. Such data is available to you in helping to solve individual problems.

No matter what material is employed, it must be remembered that diaphragms will eventually reach a point of fatigue and failure will occur. For example, with the motor driven units operating at 58 SPM the diaphragm flexes 3,480 times each hour or a total of 83,520 times for each 24 hour period. Although the diaphragm is supported by the contoured face of the piston, and the amount of flex or movement is distributed over a large area, the best materials will ultimately reach a point of fatigue. The useful life of a diaphragm will, of course, depend upon many different factors such as the material used, chemical or physical attack, temperature of fluid, volume pumped, etc. It will be apparent that with full piston stroke the flex or movement of the diaphragm will be greater than for lessor loads and the life thereof will be reduced accordingly.

There is such a great diversity of service for the MADDEN METRIFLOW PUMP and so many different materials used that it is almost impossible to estimate the probable life period of diaphragms. A test pump transferring a non-abrasive, non-corrosive material and equipped with the standard Neoprene diaphragm ran at full stroke continuously, 24 hours a day, for over one year without showing any visible sign of diaphragm wear.

DIAPHRAGM - REPLACEMENT

When it becomes necessary to replace a diaphragm, first loosen the two valve cap screws and remove valves (Note: It may be necessary to first disconnect both the inlet and discharge lines). Next remove the six solution head screws. The old diaphragm may now be rotated counterclockwise until the screw mounting it to the piston has been disengaged.

Reverse this procedure when installing the new diaphragm, making sure to rotate it clockwise until the screw has pulled the diaphragm snugly to the face of the piston, but with outer bolt holes matching those on the pump body.

The solution head can then be remounted, being sure to tighten the six socket head cap screws a little at a time progressively around the circle. These screws are to be tightened until the solution head is firmly snugged up against the diaphragm which, due to its resiliency, will bulge outwards slightly. Do not greatly overtighten as pump capacity could be changed and diaphragm life could be lessened.

Remount valves, being sure to tighten the two through bolts alternately a little at a time to ensure valve caps pull down evenly. Tighten only enough to prevent leaking and if gaskets have been badly compressed, replace with new ones.

PIPE CONNECTIONS - Inlet and Outlet

The caps which hold the valves in place are tapped for 3/8" NPT pipe connections except for the 90 GPH design: 3/4" vertical.

VALVE STRUCTURE and ACTION

Ball valves are supplied as standard equipment with the MADDEN METRIFLOW PUMP. A special cone valve is also available for certain applications (*See Parts List*). With both types, the inlet and discharge valve are identical in size and structure and may be interchanged as desired. The caps incorporate the piping connection and replacement for cleaning is quickly done by simply removing the two valve

cap screws. (Some installation may require disconnecting inlet and discharge lines.) When replacing screws, be sure to tighten alternately a little at a time so that caps remain parallel.

To insure a leak proof seal, gaskets are inserted at both top and bottom of the valve body. These gaskets are made of a special material which resists the action of almost every known substance. Whenever valves are disassembled, examine gaskets. If they have been substantially compressed replace with new ones rather than overtighten the two valve cap screws. Optional Teflon gaskets are also available.

Thousands of these valves are in service on Madden equipment pumping from heavy abrasive slurries to extremely corrosive fluids. Note the simplicity of this unique design. The removable seat has a conical shape and is molded from flexible materials such as Neoprene. The seat cushions the ball check and grips it to assure a positive seal. A sleeve encases and supports this flexible seat.

These valves offer much greater resistance to the cutting action of sharp abrasive materials because the resilient seat resists impingement better than hard materials such as stainless steel. The ball check will remain effective for a long period of time since it rotates in service with each closing.

Valve action governs the ability of a metering pump to perform within the minute tolerance of accuracy required.

LUBRICATING OIL

After an initial break-in period of 300 - 500 hours, replace oil as a good practice to avoid potential issues from small worn off pieces of metal. Afterwards, it is suggested that the oil be changed approximately every 3,000 - 4,000 hours of normal operation. **REPLACEMENT OIL:** ISO 460 Grade Lubricating Oil, viscosity 2300 SSU at 100°F, paraffin based.

The oil drain plug is located near the bottom of the gear case at the rear, while the oil level plug is directly above it. With the OIL LEVEL PLUG removed, oil can be added or replaced until the level reaches this hole, after which, the plug is replaced.

NEVER FILL THE PUMP COMPLETELY WITH OIL!

For easy access to the pump cavity for oil fill or inspection, remove the four screws holding the cover plate. Lift cover plate upward slightly and rotate 90 degrees, being careful not to damage the gasket. Continuous operation at low oil level or with contaminated oil will result in increased bearing wear and early failure.

NOTE: If oil level is unusually high or low, turn off pump immediately. See paragraphs "D" and "E" on page 7.

BACK PRESSURE REQUIREMENTS

Your Metriflow pump requires a small amount of back pressure in the discharge line to quickly seat the check valve balls for accurate metering. If the discharge line does not have adequate back pressure, install a check valve in the discharge line that will create 25 to 50 psi of back pressure, or install a spring loaded M200 valve on your pump.

PUMP REPAIRS

Complete repair service is available at the factory and at some local distributors. Repair instructions for your own in-house repairs can be obtained from the factory.

CALIBRATION

The output of your pump is sensitive to several factors which require you to calibrate your pump to determine the expected output at each dial setting. The viscosity of the fluid being pumped, back pressure on the discharge line, suction pressure or suction lift, all effect pump output. To calibrate the pump: 1.) measure the amount of flow from either the suction end, or at the end of the discharge line, 2.) measure the time it takes to pump the measured flow, 3.) convert the output to gallons per hour, 4.) record the output for all expected dial settings.

OUTPUT CHART - WATER @ 100 PSI

Model GPH	5	10	18	36	60
Dial	GALLONS PER HOUR PER PUMPING HEAD				
10	*	*	*	*	*
20	*	*	*	*	*
30	0.8	1.0	1.9	3.8	4.2
40	1.1	2.6	4.2	8.3	12.6
50	2.1	4.4	6.9	13.3	20.7
60	2.5	5.5	9.6	18.4	30.6
70	2.9	6.5	11.0	21.0	36.8
80	3.8	7.8	13.8	24.6	42.0
90	4.6	9.0	16.4	30.6	48.3
100	5.3	10.2	18.1	35.6	59.2

Capacities given in chart are approximate, always calibrate per your site conditions.

* Minimal capacities are subject to variation

PARTS LIST

(See Diagrams on Pages 5 & 6)

Item	Part No.	Qty Req'd	Description
1	MP010	1	Gear case
2	MP011	1	Side flange, for gear case
3	MP012	1	Bushing for side flange (also used in pump body)
4	MP013	2	Gasket, gear case

5	MP073	4	Screws, pump body to gear case, HH 7/16"-14 X 7/8"
6	MP014B	4	Screws, side flange to gear case, HH 7/16"-14 X 3/4"
7	MP015	1	Bearing cap, blind
8	MP016	1	Bearing cap, open
9	MP017	1	Oil seal

10	MP018	2	Oil feed tube
11	MP019	2	Tapered roller bearing
12	MP020A	2	Gasket set, bearing cap
13	MP021	8	Screws, bearing cap, HH 1/4"-20 X 5/8"
14	MP022	2	Oil plug for gear case
15	MP023__	1	Worm gear, "A" = 5 & 10 GPH, "C" = 9 & 18 GPH, "D" = 36 & 96 GPH, "E" = all other pump model flow rates.
16	MP024	1	Set screw, worm gear, SH 5/16"-18 X 5/16"
17	MP025__	1	Worm drive shaft, "A" = 5 & 10 GPH, "C" = 9 & 18 GPH, "D" = 36 & 96 GPH, "E" = all other pump model flow rates.
18	MP026	1	Woodruff key, worm drive shaft for coupling
19	MP027__	1	Pump drive shaft, "A" = simplex, "B" = duplex, "C" = triplex, "D" = quad
20	MP028	2	Woodruff key, pump drive shaft
21	MP029__	1	Pump body, "A" = left hand (standard), "B" = right hand
22	MP012	3	Bushing for drive shaft, installed in pump body
23	MP031	1	Expansion plug
24	MP032__	1	Eccentric, "A" = 5 & 9 GPH, "B" = 10, 18, 36, 54 & 60 GPH, "C" = 90, 96 & 150 GPH, "D" = 180 GPH, "E" = 125 GPH
25	MP024	1 OR 2	Set screw, eccentric, SH 5/16"-18 X 5/16"
26	MP034__	1	Connecting rod, "1" = standard, "2" = 9 & 18 GPH, "3" = 180 GPH
27	MP034__	1	Connecting rod assembly, "A" = standard, includes parts M-34, 35, 36, 37, 41, 42, 43, & 44, "B" = 5 & 9 GPH, "C" = 180 GPH
28	MP035	1	Bushing, connecting rod
29	MP036__	1	Screw, stroke adjusting, "A" = 5 & 9 GPH, "B" = standard, "C" = 180 GPH
30	MP037	1	Set screw, stroke adjusting screw, SH 10-32 X 1/4"
31	MP136	1	Primary Piston, MH Series, (9/16"). This part is also used for MF series pumps w/ type <u>DDB double diaphragm set up.</u>
32	MP038	1	Primary Piston, MF Series, (5/16"), for <u>single/simplex diaphragm set up.</u>
33	MP039	1	Wrist pin
34	MP040	1	Set screw, wrist pin, SH 1/4"-20 X 1/4"
35	MP041	1	Trunnion
36	MP042	1	Bushing, trunnion
37	MP043	2	Slide screw

38	MP024	4	Set screw, for slide screw, SH 5/16"-18 X 5/16"
39	MP045	1	Dial cover screw, fillister head 6-32 X 3/4"
40	MP047	1	Dial gear with M-56 dial scale, specify pump model
41	MP048	1	Flexible shaft
42	MP049	1	Name plate
43	MP049A	1	Name plate assembly, incl all parts M-45 to M-58, except M-48
44	MP050	4	Screw, name plate, oval head 10-32 X 1/2"
45	MP051	1	Gasket, name plate
46	MP052	1	Adjustment knob
47	MP052A	1	O-ring for Adjustment knob
48	MP053	2	Set screw, adjustment knob, SH 10-32 X 1/2"
49	MP054	1	Retaining ring, adjustment knob
50	MP055	1	Dial cover
51	MP056	1	Dial scale
52	MP057	1	Drag spring
53	MP058	1	Drag spring ball
54	MP059__	1	Diaphragm, "A" = Neoprene, "C" = Hypalon, "D" = Viton, "E" = Teflon faced Neoprene, "G" = EPDM
55	MP064B	1	Solution head, 316 stainless steel (old style is p/n MP064B1)
56	MP065	6	Screw, metal solution head, SH 3/8"-16 X 1", SS
57	MP0662B	1	Valve cap, outlet, 316 SS, 3/8" NPT
58	MP0663A	1	Valve cap, outlet, 316 SS, 3/4" NPT, vertical
59	MP0664A	1	Valve cap, outlet, 316 SS, 1/2" NPT vertical
60	MP0665A	1	Valve cap, outlet, 316 SS, 3/4" NPT vertical, MH Series
61	MP0672B	1	Valve cap, inlet, 316 SS, 3/8" NPT
62	MP0673A	1	Valve cap, inlet, 316 SS, 3/4" NPT, vertical
63	MP0675A	1	Valve cap, inlet, 316 SS, 3/4" NPT vertical, MH Series
64	MP068__	2	Screw-Valve Flange, "A" = 6", "B" = 7", "C" = 8"
65	MP070	1	Motor mounting bracket, *add "C" if 140 series motor frame
66	MP071	1	Support screw, motor mounting bracket, 5/16"-18 X 2.5"
67	MP072	1	Lock nut for support screw MP071, 5/16"-18
68	MP073	3	Screw, hex head, MP070 to MP010, HH 7/16"-14 X 7/8"
69	MP0802A	1	Coupling, flex, 5/8" X 5/8", L075, 56 frame motor, MH Series

70	MP0802B	1	Coupling, flex, 5/8" X 5/8", L070 for 56 frame motor, MF Series
71	MP0802C	1	Coupling, flex, 5/8" X 7/8", L075, 145 frame motor, MH Series
72	MP0812A	1	Spider, rubber, for L070 (4 prongs)
73	MP0812B	1	Spider, rubber, for L075 (6 prongs)
74	MP082D	1	Coupling Guard, Complete Assembly
75	MP083	2	Screw for coupling guard, SH 1/4"-20 X 3/8"
76	MP100__	2	Valve body sleeve, "A" = 304 stainless steel, "C" = PVC, "D" = Polypropylene, "E" = Kynar
77	MP101E	2	Valve seat, Teflon (standard)
78	MP102__	2	Valve ball, "A" = 316 stainless steel, "B" = ceramic, "D" = Teflon
79	MP103	2	Valve cushion, Teflon
80	MP104_	4	Valve gasket, "A" = Garlock 3000, Buna, "B" = Gortex, Teflon, "G" = EPDM
81	MP109A	2	Valve spring, M-200 type valves, 316SS
82	MP120__	1	Solution head, "A" = PVC, "B" = Teflon, "C" = Polypropylene
83	MP121	1	Face flange for plastic solution heads, stainless steel
84	MP122	6	Screw, plastic solution head, HH 3/8"-16 X 2.75", SS
85	MP1232A	2	Inlet/outlet, PVC, 3/8" NPT
86	MP1232B	2	Inlet/outlet, Kynar, 3/8" NPT
87	MP1232C	2	Inlet/outlet, polypropylene, 3/8" NPT
88	MP1233A	2	Inlet/outlet, PVC, 3/4" NPT vertical
89	MP1233B	2	Inlet/outlet, Kynar, 3/4" NPT vertical
90	MP1233C	2	Inlet/outlet, polypropylene, 3/4" NPT vertical
91	MP1234A	2	Inlet/outlet, PVC, 1/2" NPT vertical
92	MP1234B	2	Inlet/outlet, Kynar, 1/2" NPT vertical
93	MP124	1	Valve flange, outlet, for plastic solution heads
94	MP125	1	Valve flange, inlet, for plastic solution heads
95	MP126__	2	Screw-Valve Flange, "B" = 10", "D" = 9", "E" = 11"
96	MP133	6	Screw, plastic head DDB dbl diaphragm, HH 3/8-16 X 3.75"
97	MP134__	1	Type DDB double diaphragm, secondary backup, "A" = Neoprene, "C" = Hypalon, "D" = Viton, "G" = EPDM
98	MP136	1	MH series primary piston (9/16" - 12 thread)

99	MP140B	1	Spacer, Type DDB dbl diaphragm, w/ plugged drain hole, PVC
100	MP141	1	Secondary piston, Type DDB double diaphragm
101	MP165	6	Screw, metal solution head with DDB double diaphragm

Figure # 1 – 316 SS Wetted End

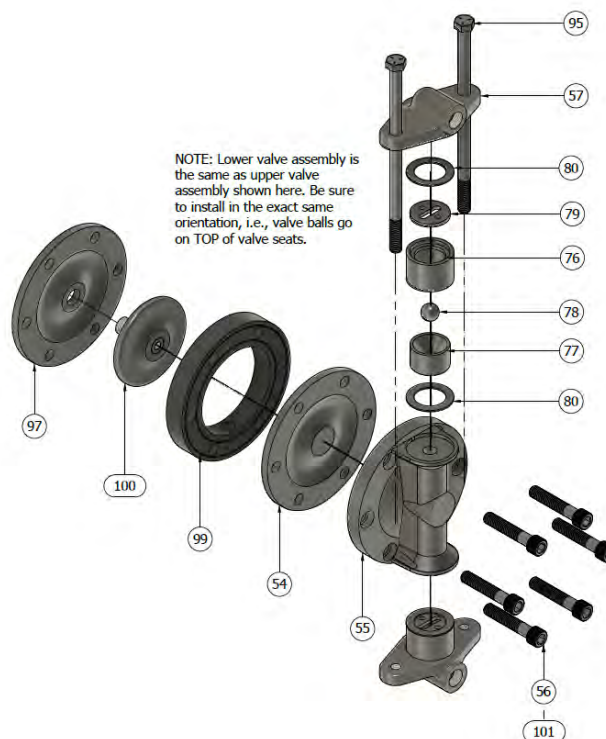
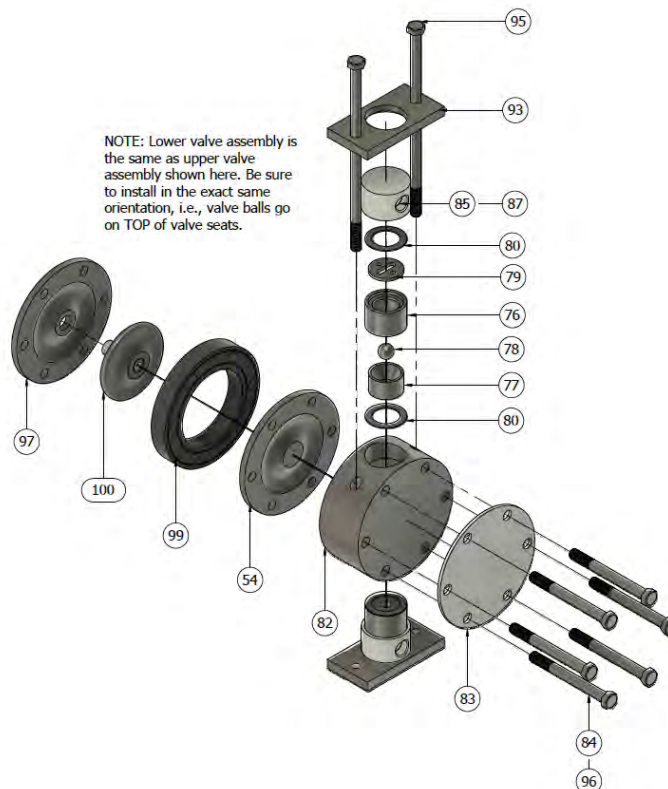
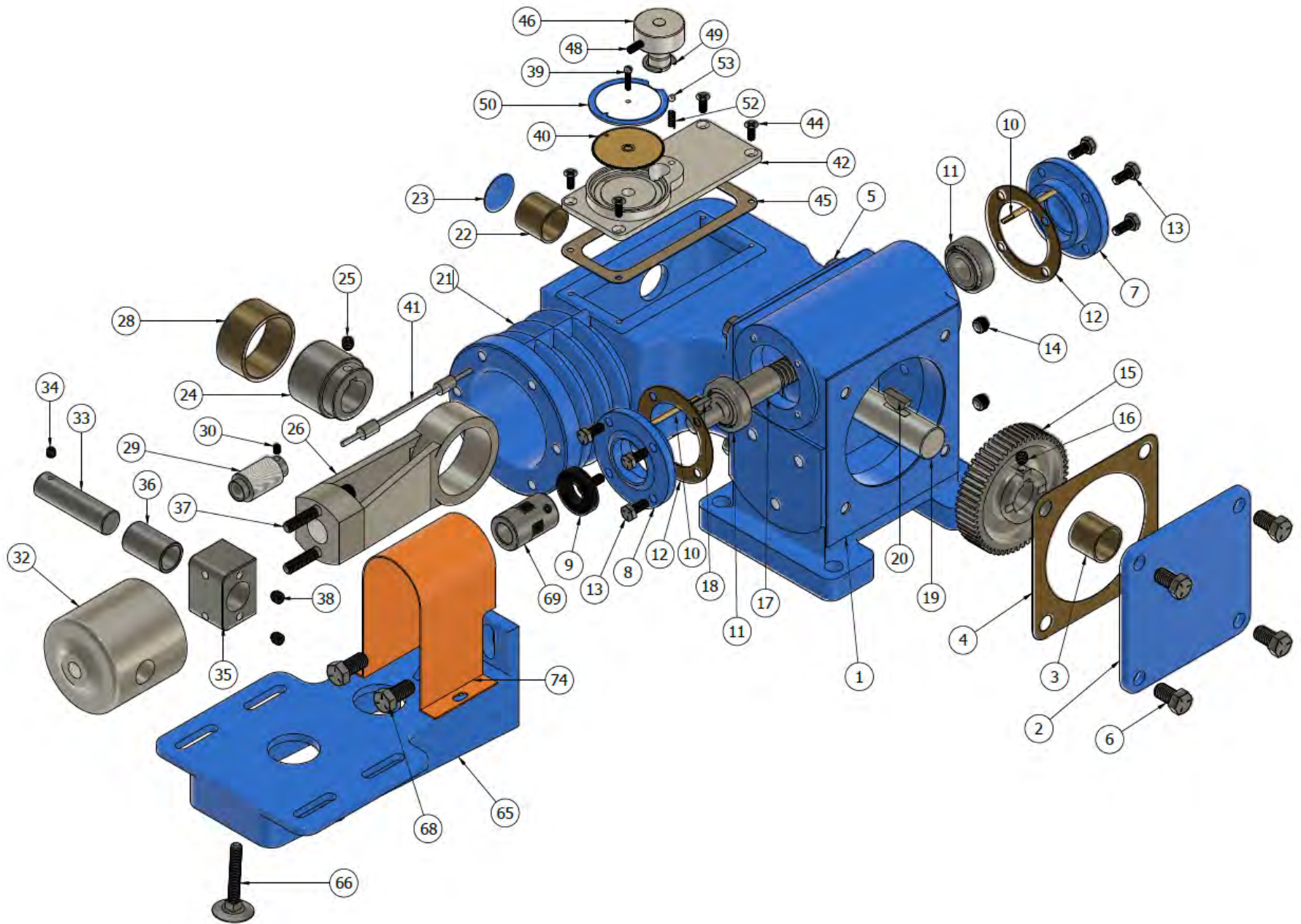

Figure # 2 – Plastic Wetted Ends



PARTS LIST – FIGURE # 3



TROUBLE SHOOTING GUIDE

ISSUE	RESOLUTIONS
- A - Discharge from pump has stopped, reduced, or become intermittent.	<ol style="list-style-type: none"> 1. Supply line valve has been closed, or Adjustment Knob has been moved. 2. Adjustment Knob flexible shaft is broken. This allows knob to spin free and stroke adjusting screw to back off reducing output. Replace MP048 Flexible Shaft. 3. Supply or discharge line has become completely or partially clogged 4. Obstruction in pump valves. Remove valve caps and clean valve seats of trash. 5. Supply tank empty. 6. Possible air entrainment in supply line or pump. Bleed trapped air out. 7. Leak in supply line. 8. Lift of solution is in excess of pump vacuum capacity. 9. Ruptured diaphragm or broken diaphragm screw. Be sure to check for contamination of solution by pump lubricating oil; likewise for contamination of oil by solution. Replace diaphragm. A new diaphragm will require 24 - 48 hours of break-in time until full rated output volume can be pumped. <p>Continuous operation of pump under these conditions could lead to increased diaphragm or valve wear. In the case of No. 1, 3, or 8, the pump may have been operating under excessive vacuum conditions and the diaphragm should be inspected for wear or possible rupture.</p>
- B - Discharge volume greater than rated capacity.	<ol style="list-style-type: none"> 1. If a new diaphragm has been recently installed, overtightening of the six solution head screws could result in excessive compression of the diaphragm. This distortion of the "working area" could give a slight capacity increase and might result in excessive diaphragm wear. 2. Back pressure on the discharge line is too low. <i>See page 5.</i>
- C - Pump drive motor has stopped although switch is on NOTE: turn electrical current off immediately!	<ol style="list-style-type: none"> 1. If discharge valve is shut off or discharge line should become clogged while pump is running, it will result in the suction stroke operating up to full capacity without a compensating discharge. The result will be excess pressure created during the power stroke of the piston. Overloading or "stalling" of the drive motor will quickly follow. If not properly fused, motor could burn out, excessive strain will be put on all working parts and the diaphragm could be badly weakened or ruptured. 2. Check for "normal" motor failure causes, ie: faulty switches or wiring, blown fuses, etc.
- D - Overflow of lubricating oil around Stroke Adjustment Knob and through air vent hole.	<ol style="list-style-type: none"> 1. Pump body and gear case cavity is normally half filled with lubricating oil and overflow through the top of pump would be impossible. Check immediately for ruptured or leaking diaphragm. Contamination of oil by solution, solution by oil, or both, would follow. If oil is contaminated by a solution that is either abrasive or corrosive, serious damage to pump, gear case, and all working parts of both could result.
- E - Drop in lubricating oil level.	<ol style="list-style-type: none"> 1. Same as item "D". 2. Leakage at oil plugs or oil seals.

