

### Accurate, Dependable Metering Pumps for Liquid Chemicals



- Pg 1 - General Overview
- Pg 2 - Dimensions, Spec's, Materials
- Pg 3 - Part Numbering Format
- Pg 4 - FAQ's & FYI's

These simple, rugged, accurate pumps are used in many industrial plants for injecting a controlled flow of highly reactive liquids such as acids, caustics, and water treatment chemicals. Heavy duty industrial grade construction means these tough little pumps will deliver many years of trouble free 24-7-365 pumping.

- ✓ MF Series pumps are designed for +/- 1% steady state repeatable accuracy over a 10:1 turndown range.
- ✓ Manual output control knob is located on top of the pump for easy access.
- ✓ Automatic pump output control is available for pumps equipped with variable speed motor and variable frequency drive
- ✓ Industrial grade worm gear reducer is integral with the pumping mechanism. Precision internal pump parts run in an oil bath for extended service life. No external lubrication required.
- ✓ Double diaphragm option is available for superior protection from dangerous liquids.
- ✓ When equipped with the proper materials the MF Series pumps are excellent for pumping dangerous liquids such as acids, caustics, and solvents. Liquids with suspended solids such as diatomaceous earth and lime slurry can be accurately pumped.
- ✓ Standard motors are industrial grade 1/3 to 3/4 HP, 56 frame, foot mounted TEFC. Motors are available for explosion proof, washdown, mill and chemical plant duty and for one or three phase, 50 or 60 Hz power.
- ✓ Tough fabric reinforced rubber diaphragms protect the drive train from the pumped liquid. The short stroke with 3" diameter piston increases diaphragm life by reducing fatigue.

*Model Number	*Output Range (GPH)	Output Range (LPH)	Standard Motor HP	Max PSI Plastic SH	Max PSI Metal SH	S.P.M.	*Piping FNPT
MF105X-XXX-XXX	0.5 - 5	1.9 - 18.9	1/3	150	300	29	3/8"
MF110X-XXX-XXX	1 - 10	3.8 - 37.8	1/3	150	300	29	3/8"
MF118X-XXX-XXX	1.8 - 18	6.8 - 68	1/2	150	300	58	3/8"
MF136X-XXX-XXX	3.6 - 36	13.6 - 136	1/2	150	300	115	3/8"
MF160X-XXX-XXX	6 - 60	22.7 - 227	3/4	150	300	172	3/8"

**Flow Rate Notes:** (1) Standard motor speed is 1,750 RPM @ 60 Hz to achieve the above flow rates. For 50 Hz motors running at 1,450 RPM, multiply the above flow range by 0.833. (2) Flow rate ranges are per pumping head, double (triple, or quadruple) total output if using a duplex, triplex, or quadruplex pump design. Also note the first '1' in the model number becomes a '2', '3', or '4'. (3) For applications that will run on the higher end of the pressure ranges and/or are dosing higher viscosities (250+ cPs), Madden recommends increasing "standard" motor HP one fractional size.

**Model Number System:** See our part numbering format tree on page 3.

**Piping Connection:** 150# RFSO flange connections are available for cost adder.

## DIMENSIONAL DIAGRAM, MF SERIES SIMPLEX PUMP

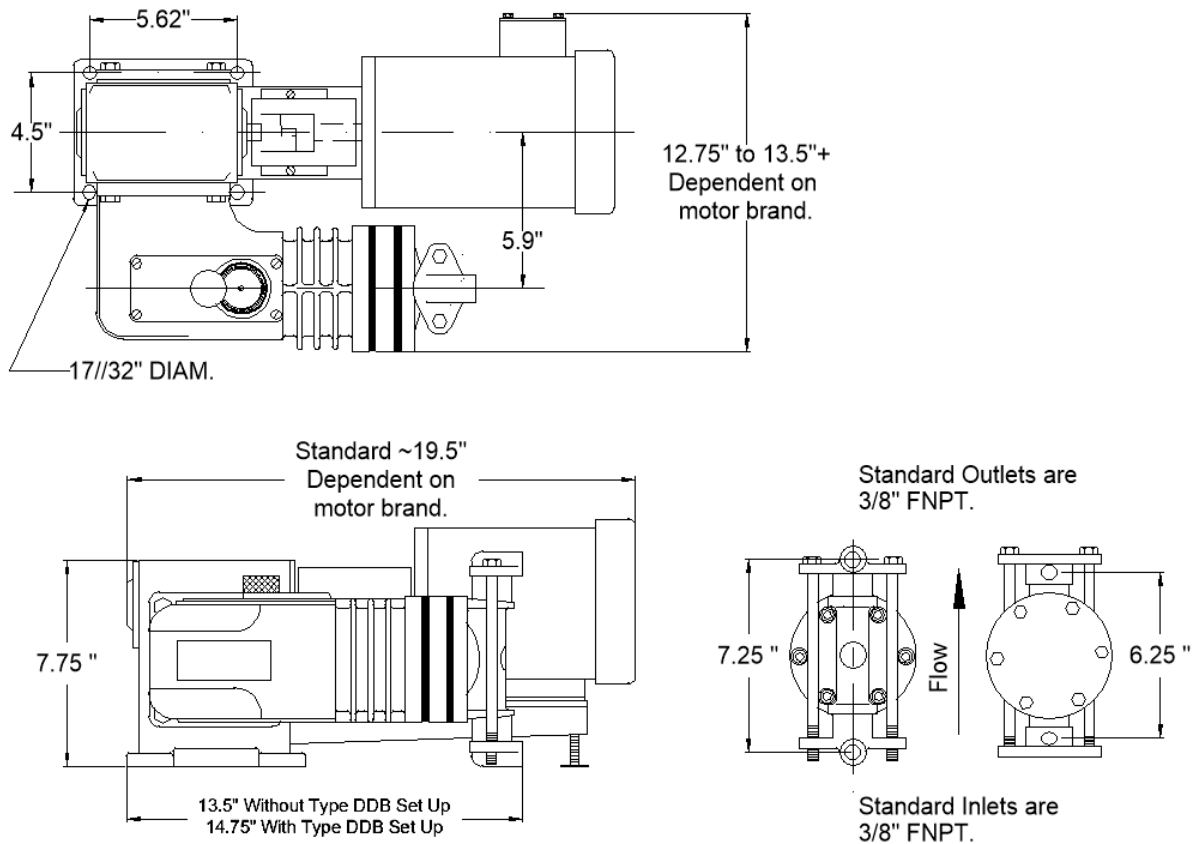

**SPECIFICATION:** The Contractor shall furnish a diaphragm metering pump as follows: (liquid), pumping rate: \_\_\_ GPH, at a maximum pressure: \_\_\_ PSI. The pump output will be adjustable from 0 to 100% while the pump is running using an adjustment knob located on the top of the pump. The pump will be of the mechanical diaphragm type with the piston directly connected to the diaphragm. Double check ball valves for both the suction and discharge connections will be included. The industrial grade gear reducer will have a bronze wheel and steel worm and will be permanently lubricated. The pump mechanism will be enclosed and running in an oil bath. No external lubrication will be required. Pump wetted end materials of construction: wetted end: \_\_\_\_, diaphragm: \_\_\_\_, replaceable valve seats: \_\_\_\_, double valve balls: \_\_\_\_, (optional: Type DDB double diaphragm will be provided for extra protection from the pumped liquid, backup diaphragm material: \_\_\_\_.) Piping connections will be 3/8" NPT.

The motor will be 56 frame C face, directly mounted to the gear reducer, 1/3 HP, 1/2 HP or 3/4 HP, 1/60/115-230 or 3/60/230-460, 1725 rpm, TEFC. Paint finish: Manufacturer's standard acrylic enamel, or optional polyurethane top coat with epoxy primer for premium corrosion resistance.

### Available Wetted End Materials - Resist Corrosion and Abrasion

Solution Head and Valve Bodies	Primary Diaphragm	Backup Diaphragm (Optional)	Valve Balls	Valve Seats
PVC	Neoprene	Neoprene	316 SS	Neoprene
Teflon/Kynar	Teflon faced Neoprene	Hypalon	Ceramic	EPDM
316 SS	Hypalon	Viton	Hastelloy C	Teflon
Polypropylene	Viton	EPDM	Teflon	316 SS
	Teflon faced Viton			
	EPDM			

## Pump Part Number Form – MF SERIES

<b>Pump Series</b>
MF
<b>Pump Heads</b>
1 - Simplex 2 - Duplex 3 - Triplex
<b>Capacity – G.P.H.</b>
05 10 18 36 60
<b>Valve Cap Sizes</b>
2 - 3/8" NPT (standard) 3 - 3/8" + M200 SLV 4 - 3/4" NPT (vertical) 6 - " 150# RF FLG

Note: 3/8" connections face horizontally out of wetted end.

Note: M200 "SLV" stands for spring loaded valves, used for higher viscosity fluids (up to 750 cPs).

<b>Solution Head</b>
S - 316SS P - P V C T - Teflon PP - Polypropylene
<b>Primary Diaphragm</b>
E - E P D M N - Neoprene H - Hypalon V - Viton TN - Teflon-Neoprene TV - Teflon-Viton
<b>Valve Balls</b>
C - Ceramic H - Hastelloy C S - 316SS T - Teflon
<b>Valve Seats</b>
E - E P D M N - Neoprene S - 316SS T - Teflon V - Viton
<b>DDB Double Diaphragm</b>
0 - (zero) - No DDB E - E P D M H - Hypalon N - Neoprene V - Viton

Z = Custom or Special

<b>Motor H P</b>
0 - (zero) - No Motor/Cplg A - 1/3 HP C - 1/2 HP D - 3/4 HP E - 1 HP F - 1.5 HP G - 2 HP
<b>Motor Type</b>
S - Standard X - Explosion Proof W - Washdown Duty M - Mill & Chem Duty H - 50 Hz
<b>Motor Phase</b>
1 - Single Phase 2 - 12V DC 3 - Three Phase 4 - 90V DC

<b>Paint 'Upgrade'</b>
E - Epoxy-Polyurethane <i>(Enter only if applicable)</i>

Z = Custom or Special

Example.)

MF1102	-	SNSNN	-	CS1
--------	---	-------	---	-----

## Frequently Asked Questions & Madden FYI's

---

1. **FYI #1 – Using variable frequency drives to remotely control pump output:** All Madden pumps have an integral, manual stroke length adjustment that provides 10:1 turndown of output. For remote control of output we recommend using a V.F.D. installed on the pump motor. For positive displacement metering pumps using check valve systems, 15 strokes per minute is the recommended minimum to maintain +/-1% consistency and accuracy in flow. So, to know the turn down ratio available per pump model, see the SPM column in the chart on page 1, and divide it by 15. For example, an MF136\_ would offer a 7.6 : 1 turndown (115 SPM / 15 SPM) when using motor speed to control output.
2. **FYI #2 – Temperature Ratings:** For pumps with PVC solution heads, the maximum temperature rating is 140 deg F. For pumps with 316SS, PP, and Teflon solution heads, the maximum temperature rating is 200 deg F.
  - a. Madden can design wetted ends to safely handle temperatures up to 300 deg F using Viton diaphragms, Teflon solution heads, and a Type DDB double diaphragm set up with a PTFE spacer. The Viton diaphragm and PTFE spacer, with a backup Viton diaphragm, helps ensure the process fluid temperature will not travel back through the pump body and overheat the pump motor.
3. **F.A.Q. / FYI – Startup “issues”:** see/request our 1 page startup guide document “MadPumps\_Startup Protocol.PDF” and the operator’s manual “MF\_OpManual\_V2.1”. These documents cover the basics. However, we want to stress on this preliminary data sheet to potential customers – these pumps are designed to be very operator friendly and incur little to no downtime – they’re admittedly ‘simple’ but extremely reliable pumps – if you’re having issues with flow rate/starting up, it is **almost always due to the surrounding conditions, not the pump itself**. Here is a quick summary of the most common hiccups we see when end users call about startup/flow rate issues:
  - a. The suction side condition isn’t level or flooded, the pump is pulling up a line, which is called a suction lift. This is difficult on any pump to overcome as they are not intended to displace air, only fluid. To help with this, be sure your suction condition is truly a flooded condition if possible, or at least level with the pump inlet; otherwise, be sure to use a check valve, specifically a foot valve if available, on the bottom suction lift line to assist the pump in starting up and maintaining flow. You may need to manually prime the pump the first time you start up if a suction lift condition is unavoidable. Madden pumps are only self-priming with a level or flooded suction condition, or after a suction lift has been primed and a foot valve is installed.
  - b. Adjustable relief valve isn’t “set” – occasionally an adjustable relief valve is left at little to no spring pressure and the pump is simply relieving itself without the operator noticing.
  - c. Rearranging of the valve assembly – it isn’t very common, but occasionally we do find person “A” at the job site had opened the valve assembly to try discover an “issue”, and then unknowingly reinstalled the check valves upside down. A person “B” then ends up calling us and isn’t aware of this – we’ll think we’ve discovered the real issue, and then be disheartened when it doesn’t work. Only to eventually find this was the reason why. Upside down check valves won’t “check”, and thereby will not draw and discharge fluid through the solution head.
  - d. Overthinking - we do not mean to patronize anyone at all, but often it’s the simplest thing imaginable that causes no flow or diminished flow issues when it comes to “simple” positive displacement type pumps. Double check valves are installed in the correct orientation, no on/off type valves are in the off position, and that new pipe dope or tape, or even new pipe metal shavings aren’t stuck in the pump inlet, Etc.
4. **F.A.Q. / FYI – Special inlet/outlet connections:** Madden is often requested to build pumps with integral class 150 RF flange connections, which can be provided for a cost adder. We can also provide special, custom machined plastic material flange connections; for example, Madden has made custom Teflon inlet and outlet connections to mesh with a standard 150# flange pattern, for steal pipe with a Teflon liner for extremely corrosive fluids like Sulfuric Acid.
  - a. Please reach out to the factory if you have a special inlet/outlet connection request.
5. **F.A.Q. / FYI – Viscosity ratings:** Madden MF series pumps have been tested with fluids up to 250 cPs viscosity with little to no reduction in output and accuracy. For viscosities between 251 to 750 cPs, we recommend our M-200 spring loaded valve assembly. As a general rule of thumb, end users should expect up to 10% flow reduction and 5% accuracy reduction when viscosity of fluid is thicker than 500 cPs - with M200 spring loaded valves, an MF pump should maintain flow rate up to 500 cPs.

